

# SMARTACCESS

## Operation Manual

TBD – Druckansicht Deckblatt – noch zu befüllen

# TABLE OF CONTENTS

- 1. 1. SmartAccess**
- 2. 2. General Information**
- 3. 3. Setup**
- 4. 4. Lock Settings**
- 5. 5. Add & manage Keys**
- 6. 6. My Key Settings**
- 7. 7. Add & edit Profiles**
- 8. 8. Add & edit Access Schedulers**
- 9. 9. Events**
- 10. 10. Door Modes**
- 11. 11. SmartKeys**
- 12. 12. How does KeylessGo works**
- 13. 13. Reset (Factory Settings)**
- 14. 14. Firmware Update**
- 15. 15. Downloads SmartAccess**

# 1. SMARTACCESS

## SmartAccess

### Bluetooth Access Control System



- Turn your smartphone into a digital AppKey
- For FUHR motorised locks and other doors and gates
- Easy retrofitting, straightforward setup, simple operation
- Fast door opening without internet, without cloud
- Extensive SmartAccess system landscape with expansion options

**SmartAccess** is a state-of-the-art Bluetooth access control system with KeylessGo technology. It allows the convenient, keyless opening of doors and gates. Via the **SmartAccess App** you can easily turn your smartphone into a digital AppKey and activate additional physical SmartKeys. The motor locks are unlocked just by touching the door handle or a sensor in combination with your smartphone or an activated SmartKey nearby. And **SmartAccess** goes beyond. With Auto unlock enabled your door automatically unlocks if you approach the door with your smartphone in your pocket.

#### 1.1. SmartComponents

### SmartAccess Module "SAM"

#### Compact SmartAccess Bluetooth Transceiver



- Smart universal module with connection to 12/24V DC, adjustable switching output, switching input for status feedback and BUS connection
- Compatible with FUHR motor locks multitronic 881 and autotronic 834/836 and certain locks of other manufacturers
- Particularly easy to retrofit: Thanks to flexible retrofittable front plates – SAM makes every door smart
- Seamlessly built into the door leaf – directly on the motor drive
- For doors, gates and other applications like electric strikes or garage door openers thanks to the additional switching output and input
- Easy configuration via the SmartAccess app

**SmartAccess app**  
Open doors easily

- Turns your smartphone into a digital AppKey
- Independent of Wi-Fi or mobile network connection
- Simple key management and temporary user invitations
- Status notifications and journal
- Auto-Unlock function when approaching the door
- Activation of different Door modes
- Optional KeylessGo function with respective SmartTouch handles or sensors

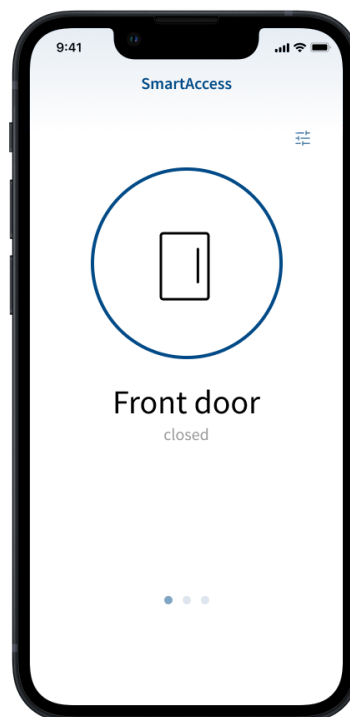

## **SmartAccess Access Control**

One System, many options



- **SmartAccess SmartKey:** classic access with radio SmartKey
- **Multiscan SmartAccess:** finger scan with modern area sensor (coming soon)
  
- **SmartAccess App:** opening via SmartAccess app or when approaching the door
- **Smart Access SmartTouch:** Activation of the KeylessGo function by approaching with an active SmartKey or smartphone

## SmartAccess + SmartTouch KeylessGo for the door



- Simply touch the SmartTouch handle, SmartTouch sensor field, or SmartTouch door fitting and enter
- Activate the KeylessGo function by approaching with the active SmartAccess SmartKey

**NEW:** Activation of the KeylessGo function by approaching with the smartphone

## 2. GENERAL INFORMATION

### 2.1. Scope of delivery

- SmartAccess Module „SAM“
- SmartAccess Security Card

#### Optional

- SmartAccess SmartKey
- SmartTouch handle or SmartTouch sensor in different shapes

### 2.2. Function

**SmartAccess** allows you the convenient door opening via KeylessGo technology. Therefore it is sufficient to carry your authorised smartphone or an activated SmartKey. For unlocking the door by the motorised lock, simply touch the SmartTouch handle or SmartTouch sensor. The **SmartAccess Module** usually installed into the door leaf now transmits a Bluetooth-Signal, which is received and answered by the **SmartAccess App** or an activated SmartKey. The **SmartAccess Module** checks the opening authorisation of the SmartAccess AppKey or SmartKey and then unlocks the motorised lock.

If the KeylessGo function is not desired, it can be disabled for each individual Key or completely for all. The door can then still be operated via the SmartAccess App or the SmartKey's transmit button.

### 2.3. Safety instructions for the SmartAccess Module

For the correct use of the the **SmartAccess Module**, please read the operating instructions carefully before using the product. Follow the instructions given and follow the described instructions. Failure to comply with the information and instructions, no warranty for the proper functioning of the product can be given. The **SmartAccess Module** is intended for private indoor use only and must be protected against moisture and tampering. Any other use than that described in this manual is not intended and will result in exclusion of warranty and liability. This also applies to conversions and changes to the device. Do not open this device under any circumstances! It contains no user-serviceable parts. If an error occurs, send the **SmartAccess Module** to the responsible service unit.

### 2.4. Safety instructions for the smartphone

Be sure to keep the virus scanner and firewall of your smartphone up to date. Only in this way can you be protected against attacks from the Internet. Regularly check if your software is up-to-date and install the available updates. For your safety, use good passwords and change them at certain intervals. Recommendations for secure passwords can be found, for example, at the Federal Office for Information Security in the area of Recommendations: [www.bsi-fuer-buerger.de](https://www.bsi-fuer-buerger.de) < <https://www.bsi-fuer-buerger.de/> >.

### 2.5. Notes on radio operation



The radio transmission takes place on a non-exclusive transmission path. This can lead to interference from other radio applications. Switching operations, electric motors or defective electrical appliances can also cause interference. The transmission power and reception characteristics of the **SmartAccess Module** depend heavily on constructional and ecological conditions. Thus, the range in the open field differs from that in buildings. Also, the signal is transmitted differently at high humidity than at lower humidity.

**SmartAccess** complies with the requirements and regulations of Directive 1999/5/EC.

**Note:** Please make sure that in the case of a data interruption, for example due to a power failure, relevant applications such as door locks can be operated differently (e.g. mechanically with a cylinder key).

## 2.6. Disposal information

**Old devices and batteries are not allowed to be disposed with household waste!**

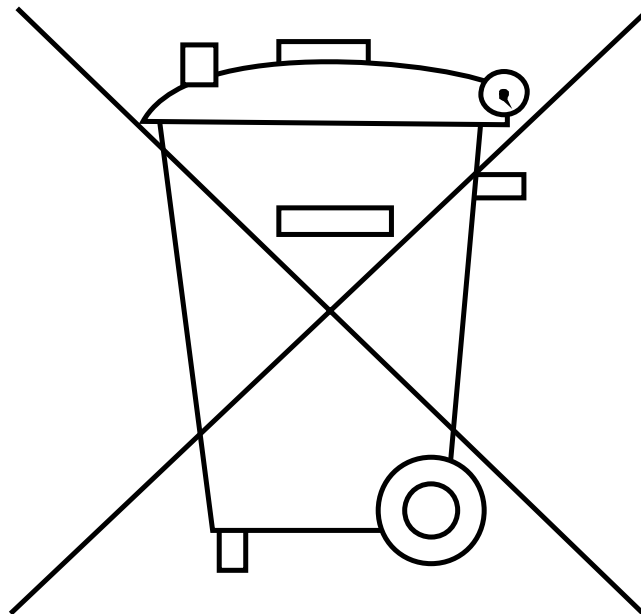

Dispose of the old devices via a collection point for electronic waste or via your specialist shop.  
Dispose of the old batteries in a recycling container for used batteries or via your specialist shop.

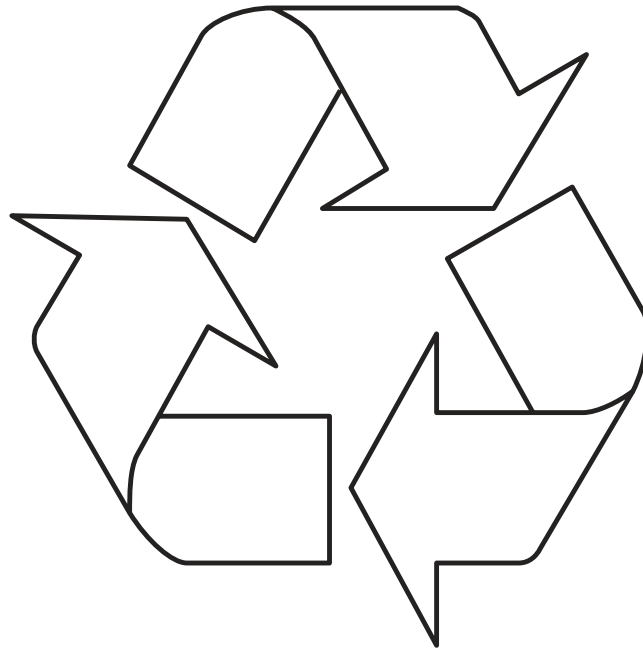

Dispose of the packaging material in the collection container for cardboard, paper and plastics.

## 3. SETUP

In order to use **SmartAccess**, it must be set up via the **SmartAccess App**.

You will need:

- **SmartAccess Module** (usually installed in door leaf)
- **Smartphone**
- **SmartAccess App**
- **Personal SmartAccess Security Card** (delivered with the SmartAccess Module)
- **SmartTouch handle** or **SmartTouch sensor** (optional to use KeylessGo and other features)

### 3.1. Download and install SmartAccess App

Download the **SmartAccess App** from the appropriate store and install the app on your smartphone.



< [https://apps.apple.com/us/app/fuhr-smartconnect/id900377387?  
itsct=apps\\_box&itscg=30200](https://apps.apple.com/us/app/fuhr-smartconnect/id900377387?itsct=apps_box&itscg=30200) >



< [https://play.google.com/store/apps/details?  
id=de.smartwireless.smartconnect&pcampaignid=pcampaignidMKT-Other-global-all-co-prtnr-py-  
PartBadge-Mar2515-1](https://play.google.com/store/apps/details?id=de.smartwireless.smartconnect&pcampaignid=pcampaignidMKT-Other-global-all-co-prtnr-py-PartBadge-Mar2515-1) >

### 3.2. SmartAccess Security Card

Set up **SmartAccess** easily and quickly with your personal SmartAccess Security Card (delivered with the **SmartAccess Module**).



SmartAccess Security Card – Front



SmartAccess Security Card – Back

**Note:** After setup is complete, keep the SmartAccess Security Card in a safe place. In case you need to reset the system, you will need your personal SmartAccess Security Card.

### 3.3. Commissioning and pairing

1 Open the **SmartAccess App** and define a secure password.

Tap **Start**.

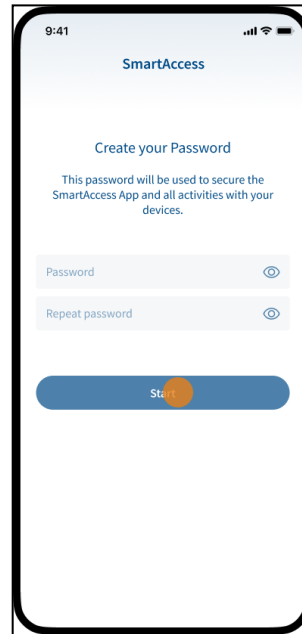

2 Tap **Set up SmartAccess Module**.

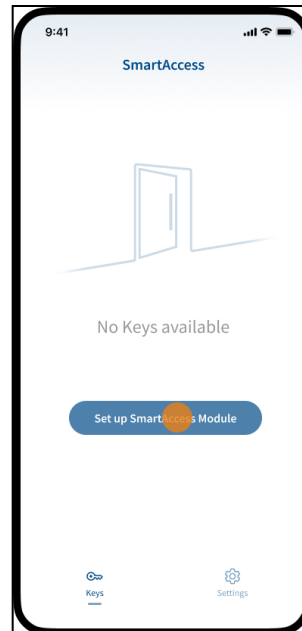

**3** Scan the QR code on the supplied *SmartAccess Security Card*.

To do this, position the QR code in the frame of your smartphone's camera.

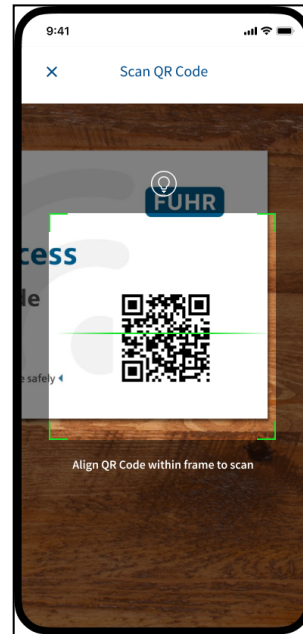

**4** 1. Press the **LED button** of the **SmartAccess Module** (usually installed in door leaf).  
The LED starts flashing.

**Note:** The **SmartAccess Module** is located behind the door faceplate. To press the **LED button** you need a thin screwdriver or similar.

2. Tap **Start Pairing**.

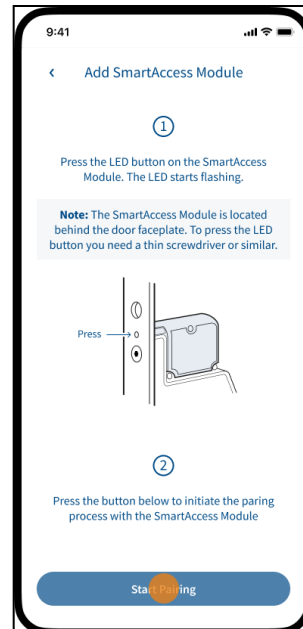

5 Wait until the pairing process is complete and then follow the steps described in the next chapter.

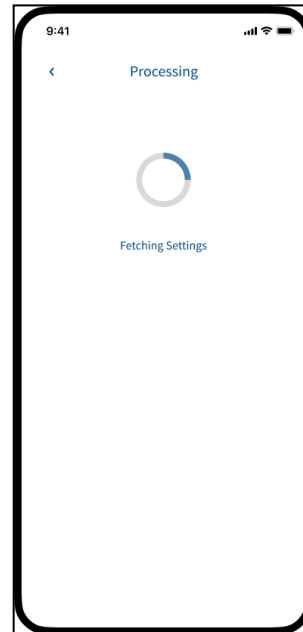

### 3.4. Basic settings

Set the basic settings by activating or deactivating the corresponding toggle switches. The basic settings can be adjusted at any time in the Lock settings area (see chapter [Lock Settings < https://docs.smartwireless.de/en/lock-settings/>](https://docs.smartwireless.de/en/lock-settings/>)). Further information about the individual features and functions can be found in the **Smart Access App** or in this user manual.

**Note:** To set or adjust the basic settings of the **SmartAccess Module**, your smartphone must be within the Bluetooth range of the **SmartAccess Module**. Please make sure that your smartphone is near the **SmartAccess Module** or door.

1 Make the basic settings by activating or deactivating the corresponding *toggle switches*.

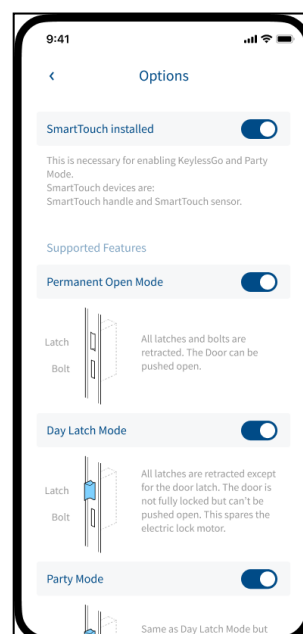

2 Scroll down and tap **Next**.

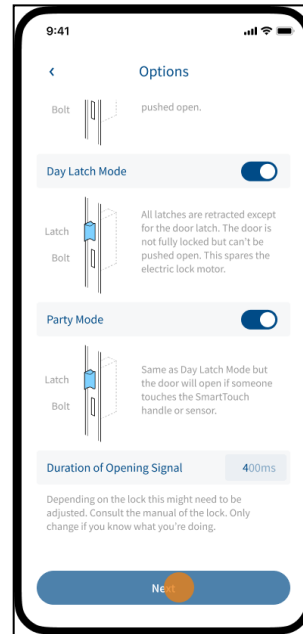

3 Confirm the pop-up by tapping **Allow While Using the App**.

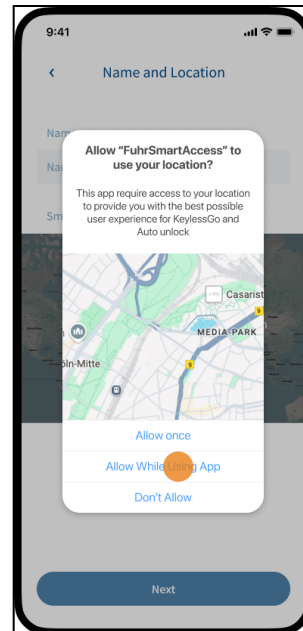



4 Confirm the pop-up by tapping **Change to Always Allow**.

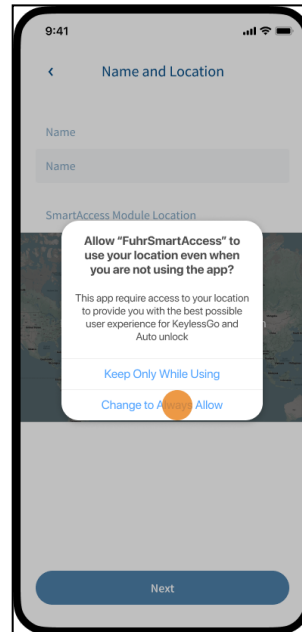

5 Assign a unique name for your **SmartAccess Module** and check that the position of the module has been set correctly.

If the position is correct, tap **Next** at the bottom.

If the position is **not** correct, tap **Edit Location** to adjust the position.

**Note:** The position of the **SmartAccess Module** and the position of your smartphone should be the same.

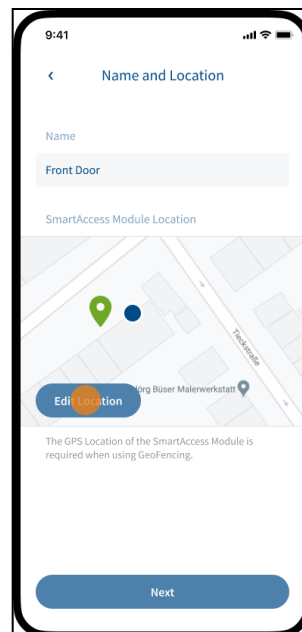

**6** You now have the option to adjust the position of the **SmartAccess Module**:

1. The **My Location button** in the top right corner shows the current GPS location of your smartphone.
2. The **Set Module Location to my Position button** at the bottom sets the position of the SmartAccess Module to the current position of the smartphone.
3. To move the pin manually, **tap the pin and drag it** to the desired position.

**7** Confirm the correct position by tapping **Save** in the top right corner.

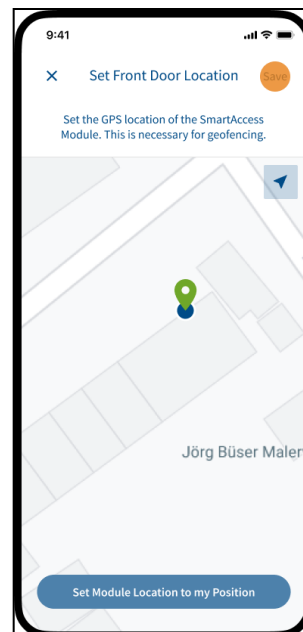
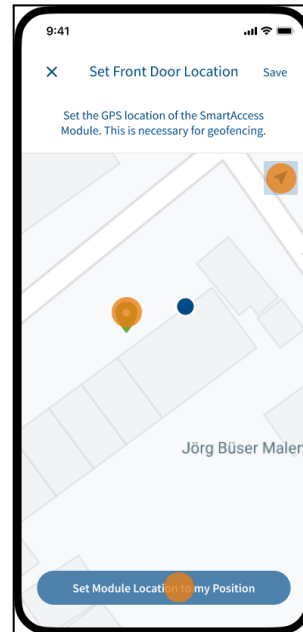

8 Tap **Done** to complete the setup process.

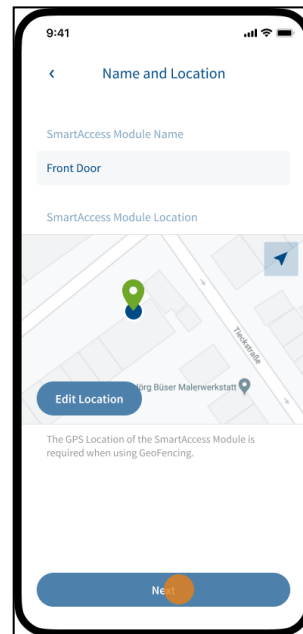

## 4. LOCK SETTINGS

In the Lock settings area you have the possibility to adjust the basic settings of the **SmartAccess Module**. E.g. change the name, edit the location, adjust the geofence radius and the Bluetooth signal strength or activate/deactivate supported door modes like Day Latch Mode, Permanent Open Mode or Party Mode. Further more you can adjust the duration of the opening signal, do a firmware update or reset the device.

**Note:** To access or adjust the Lock Settings, your smartphone must be within the Bluetooth range of the **SmartAccess Module**. Please make sure that your smartphone is near the **SmartAccess Module** or door.

1 Tap the **three dots icon** in the top right corner and choose **Lock Settings**.

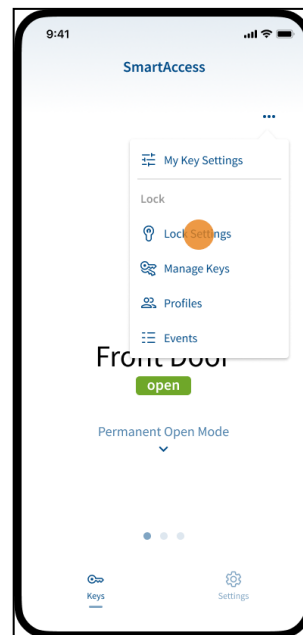

2 You now have the possibility to adjust the basic settings for the **SmartAccess Module**.

To activate/deactivate features use the **corresponding toggle switches**. To change the name or to adjust other settings simply tap on the **setting** and do your adjustments.

**Note:** A table with explanations of the individual settings can be found at the end of this chapter.

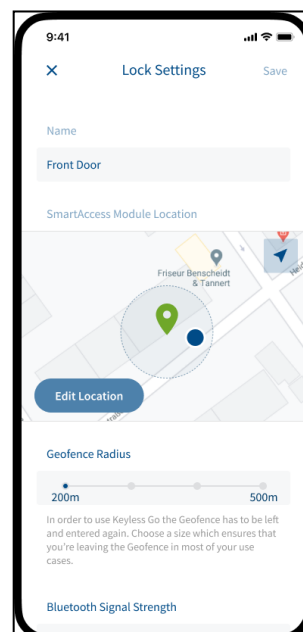

3 Scroll down to make further adjustments.

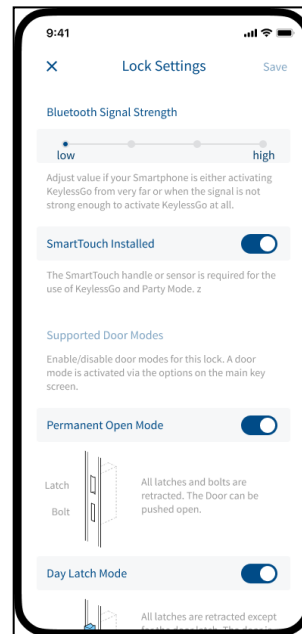

4 Scroll down to make further adjustments.

To save the changes you made, tap **Save** in the top right corner.

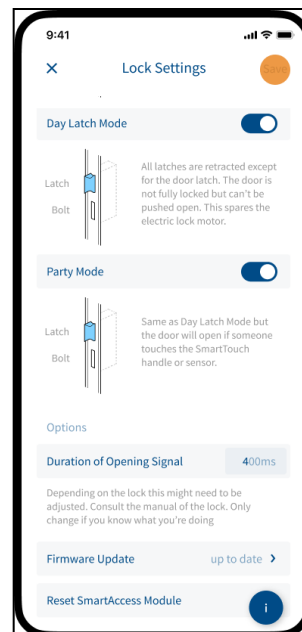

**Note:** In the Lock Settings area you have the option to enable the use of different door modes. In order to actually use a door mode, it must be activated. For further information on how to activate door modes, see chapter [Door Modes < https://docs.smartwireless.de/en/door-modes/>](https://docs.smartwireless.de/en/door-modes/).

## 4.1. Explanation of the Lock Settings

### Name

Assign a unique name for your **SmartAccess Module** integrated inside your door. If you use multiple **SmartAccess Modules**, a unique name will help you identify the right Module or door in the **SmartAccess App**.

## Geofence Radius

The Geofence area is a like fence drawn around the the **SmartAccess Module** integrated inside your door. When entering the Geofence area KeylessGo get's armed and the **SmartAccess App** starts scanning for a **SmartAccess Module**.

Further information on how KeylessGo works, see chapter [How does KeylessGo works < https://docs.smartwireless.de/en/how-does-keylessgo-work/>](https://docs.smartwireless.de/en/how-does-keylessgo-work/).

## Bluetooth Signal Strength

Adjust value if your Smartphone is either activating KeylessGo from very far or when the signal is not strong enough to activate KeylessGo at all.

## SmartTouch

A SmartTouch handle or SmartTouch sensor allows you the convenient door opening via KeylessGo technology. For unlocking the door by the motorised lock, simply touch the door handle or sensor. The **SmartAccess Module** installed into the door leaf now sends a Bluetooth signal, which is received and answered by the **SmartAccess App** (smartphone). The **SmartAccess Module** checks the opening permissions of the key (AppKey / FingerprintKey / SmartKey) and then unlocks the motorised lock.

**Note:** In order to be able to open the door conveniently with the SmartTouch handle or SmartTouch sensor, KeylessGo or a corresponding door mode must be activated in the Lock Settings area.

## Door Modes

**SmartAccess** offers the option of activating different door modes (Day Latch Mode, Permanent Open Mode, Party Mode) in certain FUHR motorlocks.

For further information about the individual door modes, see chapter [Door Modes < https://docs.smartwireless.de/en/door-modes/>](https://docs.smartwireless.de/en/door-modes/).

## Duration of Opening Signal

Depending on the lock type installed in your door, this may need to be adjusted. Please only change if you know what you are doing. If in doubt, please contact a qualified technician or your system provider.

The default value is 400ms. Minimum: 100ms, maximum: 10000ms (10sec).

## Firmware Update

The software of your **SmartAccess Module** and the **SmartAccess App** should always be up-to-date to ensure maximum security. The **SmartAccess App** is usually updated automatically via the App Store / Google Play Store.

**Note:** The **SmartAccess Module** can only be updated manually via the app if the smartphone is within the Bluetooth range of the **SmartAccess Module**. For more information, see chapter [Firmware Update < https://docs.smartwireless.de/en/software-update-2/>](https://docs.smartwireless.de/en/software-update-2/).

## Reset SmartAccess Module

A reset allows you to reset the **SmartAccess Module** to the delivery state (factory settings).

**Note:** All settings and saved keys will be lost.

## 5. ADD & MANAGE KEYS

Share access for your **SmartAccess Modul** or door with family, friends and employees. With the **SmartAccess App** you can easily invite new users to control the **SmartAccess Module** and manage their access permissions. An individual key is added and assigned for each user of the **SmartAccess Module**.

Different types of keys can be added and assigned, such as AppKeys, SmartKeys or FingerprintKeys (coming soon).

**Note:** To set the user's access permissions assign the user a profile with the desired permissions or create a new profile. For more information on how to add and edit profiles, see chapter [Add and edit Profiles < https://docs.smartwireless.de/en/profiles/>](https://docs.smartwireless.de/en/profiles/).

### 5.1. Add AppKeys

1 Tap the **three dots icon** in the top right corner and choose **Manage Keys**.

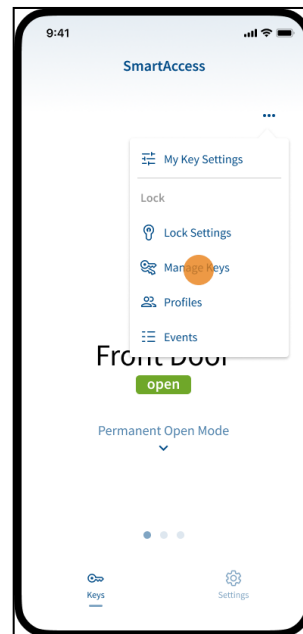



2 Tap **Add Key**.

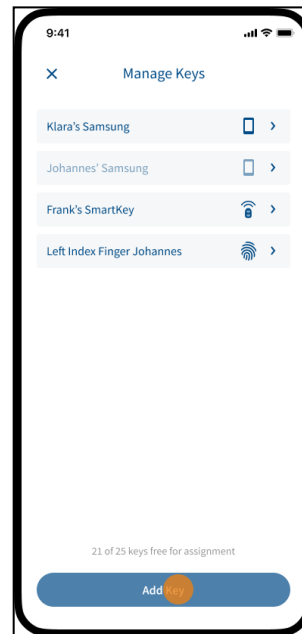

3 Assign a **Key Name**, select the key type **AppKey** and choose a **Profile**.

**Note:** For more information on how to add and edit profiles, see chapter [Add and edit Profiles < https://docs.smartwireless.de/en/profiles/>](https://docs.smartwireless.de/en/profiles/).

To invite the person tap **Next**.

The “share” menu of your smartphone will now open. Choose which service (messages, mail, messenger, etc.) you want to use to send the invitation.

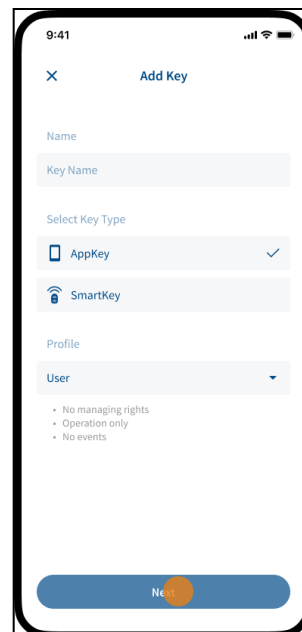

## 5.2. Add SmartKeys

1 Tap the **three dots icon** in the top right corner and choose **Manage Keys**.

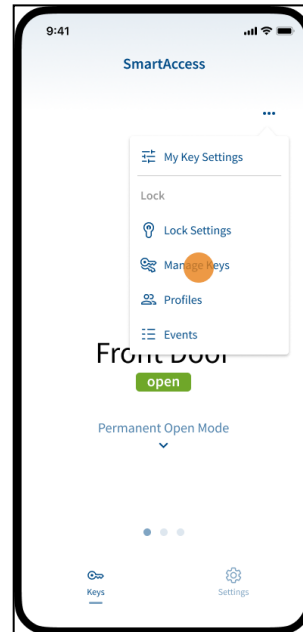

2 Tap **Add Key**.

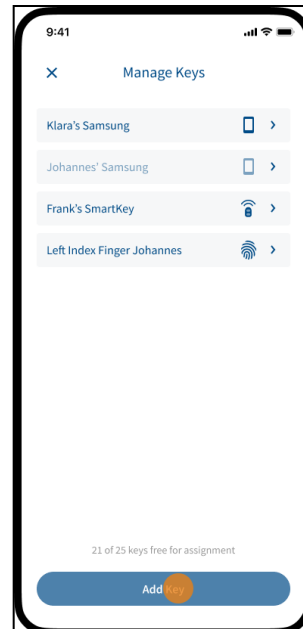

3 Assign a **Key Name**, select the key type **SmartKey** and choose a **Profile**.

**Note:** For more information on how to add and edit profiles, see chapter [Add and edit Profiles < https://docs.smartwireless.de/en/profiles/>](https://docs.smartwireless.de/en/profiles/).

To add the key tap **Next**.

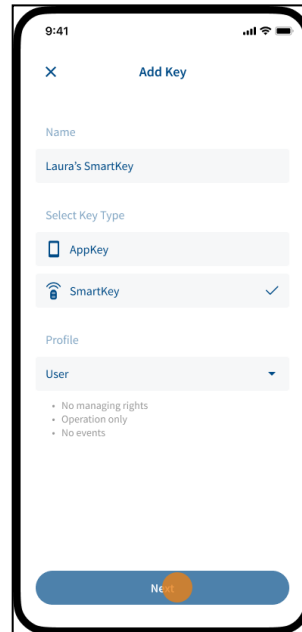

4 To access the SmartKey, it has to be set to edit mode.

To set the **SmartKey** to edit mode:

1. Make sure the SmartKey is located near your **SmartAccess Module**.
2. Press buttons 2 and 4 on the SmartKey.

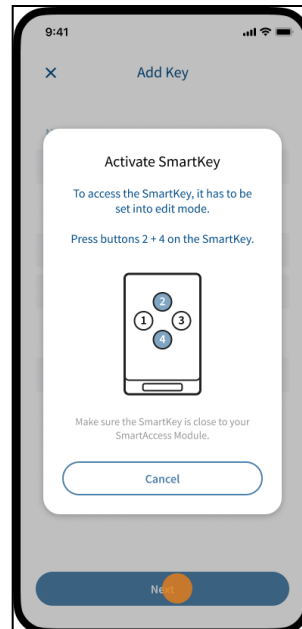

5 Wait until the SmartKey is activated.

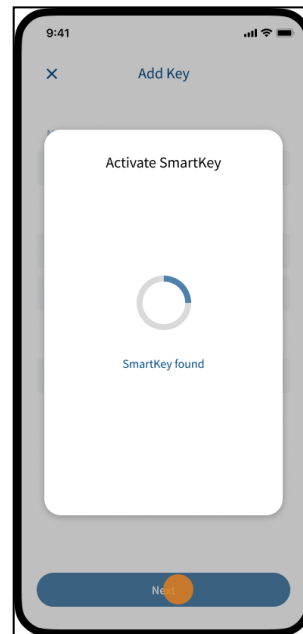

6 The button assignments of the SmartKey are displayed.

Select an unassigned button for controlling the SmartAccess Module or delete an existing button assignment first.

To select an unassigned button, tap on the corresponding **button in the graphic** or on **Assign**.

To delete an existing button assignment, tap on the corresponding **delete icon**.

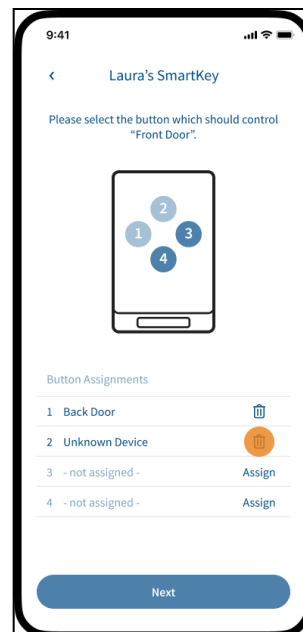

7 Confirm the pop-up by tapping **Delete Button Assignment**.

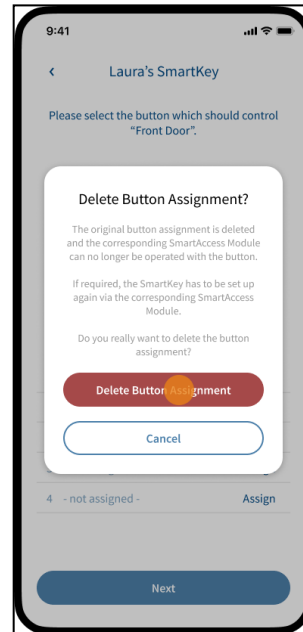

8 Select an unassigned button for controlling the **SmartAccess Module** by tapping on the corresponding **button in the graphic** or on **Assign**.

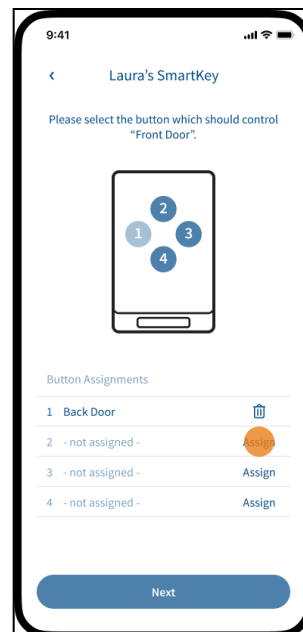

9 Tap **Next**.

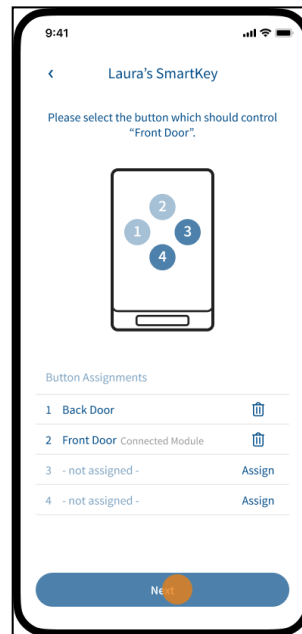

10 To complete the process the SmartKey has to be set to edit mode again.

**To set the SmartKey to edit mode:**

1. Make sure the SmartKey is located near your SmartAccess Module.
2. Press buttons 2 and 4 on the SmartKey.

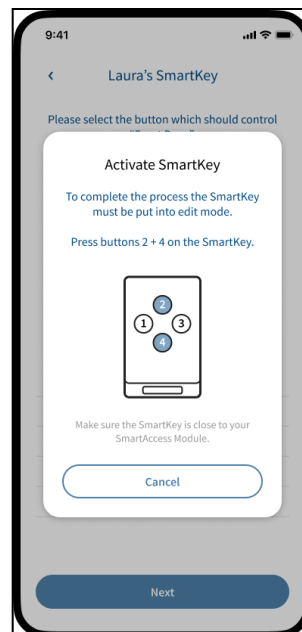

11 Wait until the SmartKey is activated.

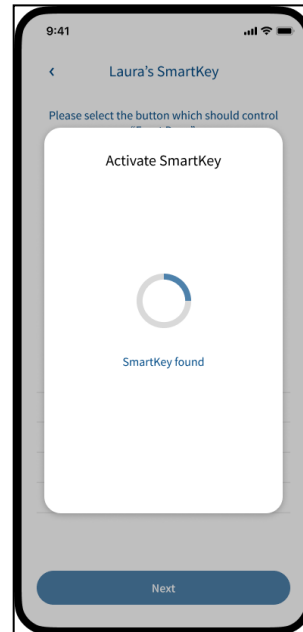

12 The button assignment has been successfully assigned.

Tap **Done** to complete the process.

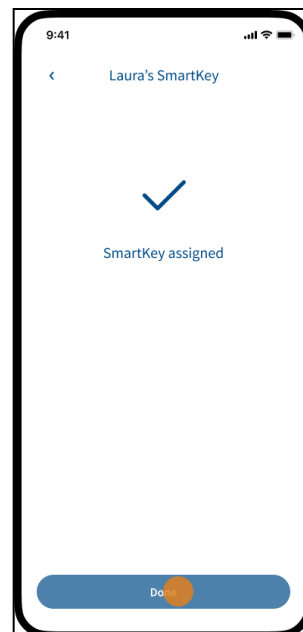

**Note:** The button assignments of SmartKeys can be individually adjusted. For more information about SmartKeys, see chapter [SmartKeys < https://docs.smartwireless.de/en/smartkeys/>](https://docs.smartwireless.de/en/smartkeys/).

## 5.3. Manage Keys

1 Tap the **three dots icon** in the top right corner and choose **Manage Keys**.

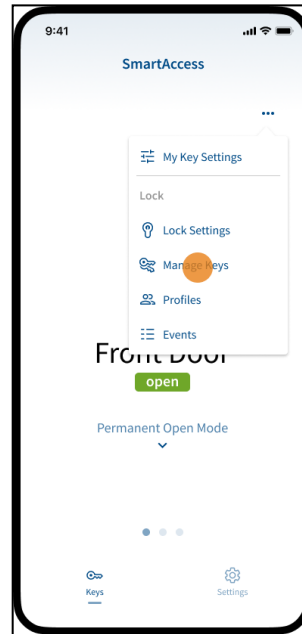

2 All keys of the **SmartAccess Module** are listed here.

Select the **key** you want to edit.

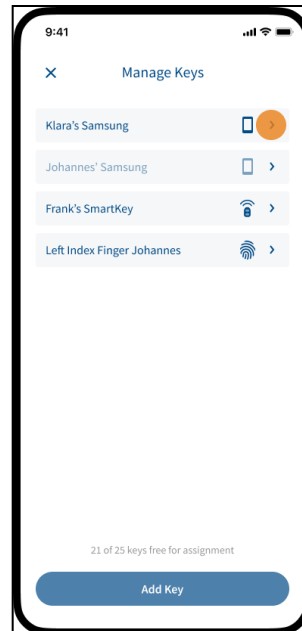



3 You can now change the **Key Name** or assign a different **Profile** to the key.

**Make your adjustments.**

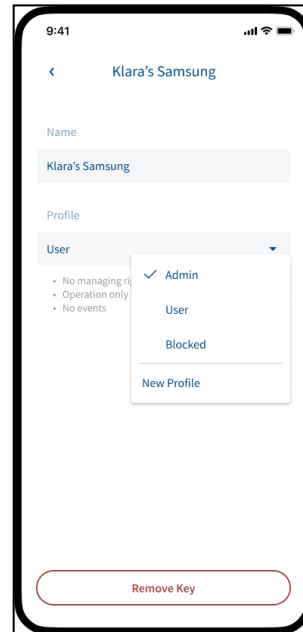

4 To save the changes you made, tap **Save** in the top right corner.

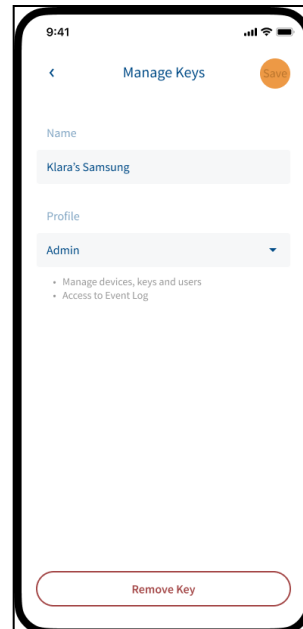

## 5.4. Remove Keys

1 Tap the **three dots icon** in the top right corner and choose **Manage Keys**.

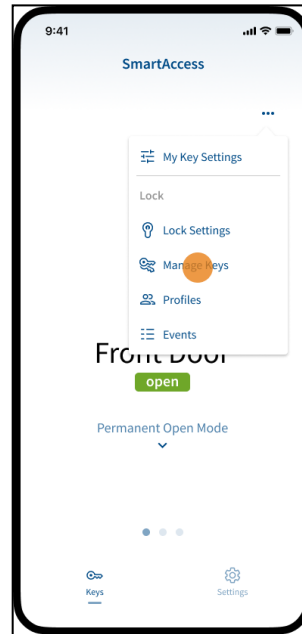

2 All keys of the **SmartAccess Module** are listed here.

Select the **key** you want to remove.

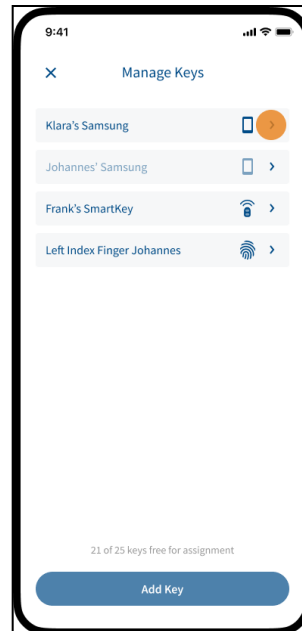

3 To remove the key tap **Remove Key** at the bottom.

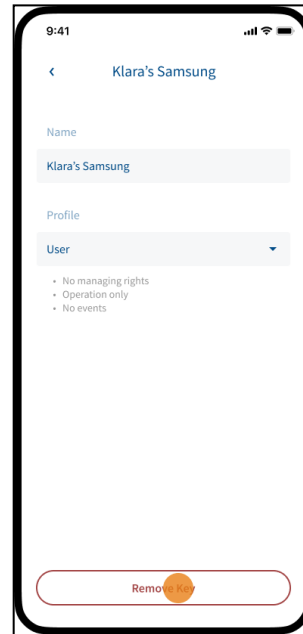

## 6. MY KEY SETTINGS

In the My Key Settings area you have the possibility to adjust the basic settings of your personal key. E.g. change the name, view the location of the **SmartAccess Module** or door, activate/deactivate supported features like KeylessGo or Auto Unlock and manage notifications.

1 Tap the **three dots icon** in the top right corner and choose **My Key Settings**.

**Note:** If you are logged in as an user the **My Key Settings icon** (instead of the three dots icon) is shown in the top right corner.

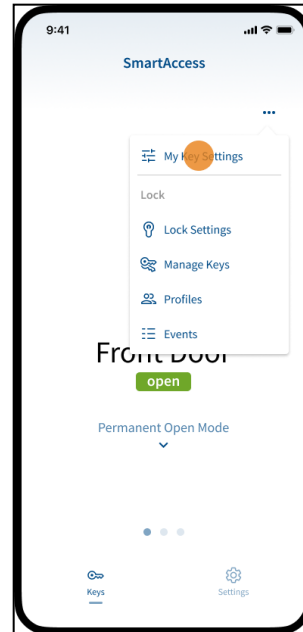

2 You now have the possibility to make different adjustments for the key. E.g. change the name, activate/deactivate features like KeylessGo or manage notifications.

To activate/deactivate features or notifications use the corresponding **toggle switches**.

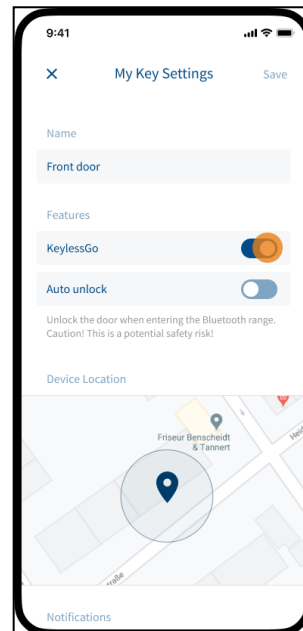

3 Scroll down to make further adjustments.

To save the adjustments tap **Save** in the top right corner.

To remove the key tap **Remove Key** at the bottom.

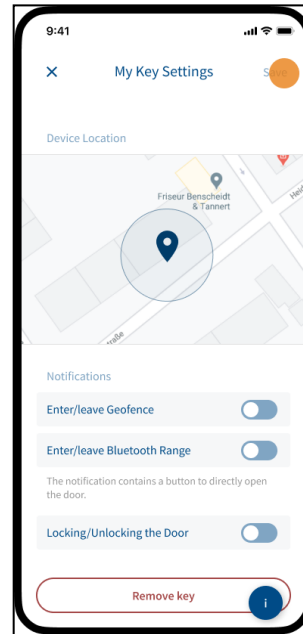

## 6.1. Auto Unlock

If Auto unlock is enabled, the door is opened as soon as the key is within the Bluetooth range of the **SmartAccess Module**. The door can be pushed open without touching the door handle or sensor.

Make sure that you actually enter the door after entering the Bluetooth range of the **SmartAccess Module**, otherwise the door will remain open! If you do not have a SmartTouch handle or a SmartTouch sensor, Auto Unlock can be used to enable similar door behavior to KeylessGo.

**Note:** Enabling Auto unlock is a potential security risk. The door will be unlocked as soon as the smartphone is within the Bluetooth area.

## 7. ADD & EDIT PROFILES

As an administrator, you have the option to assign different types of access permissions for your **SmartAccess Module** or door. By creating and assigning individual profiles with different access permissions, you have full control over the access permissions of different users.

For more information on how to assign a profile to a user, see chapter [Add and manage Keys < https://docs.smartwireless.de/en/add-users/>](https://docs.smartwireless.de/en/add-users/).

### 7.1. Add Profiles

1 Tap the **three dots icon** in the top right corner and choose **Profiles**.

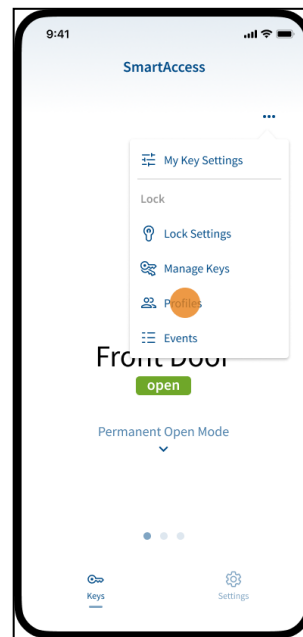

2 All profiles of the **SmartAccess Module** are listed here. The profiles "Admin" and "Blocked" are immutable and can't be removed. All other profiles can be adjusted or removed.

To add a profile tap **Add Profile**.

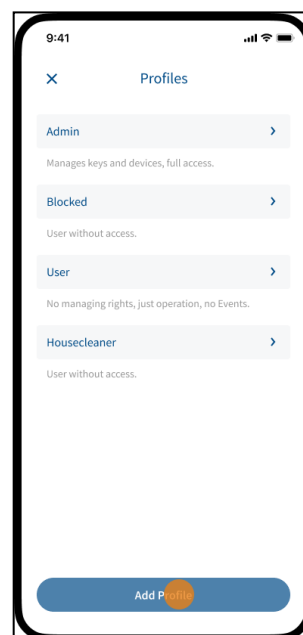

3 Assign a **name** to the profile and grant the desired permissions.

To grant permissions for features like KeylessGo and Auto Unlock or to grant permission to use door modes activate the corresponding **toggle switch**.

**Note:** A table with explanations of the features can be found at the end of this chapter.

To add an access scheduler tap **Access Scheduler**. For more information about access schedulers, see chapter [Access Schedulers < https://docs.smartwireless.de/en/access-scheduler/>](https://docs.smartwireless.de/en/access-scheduler/).

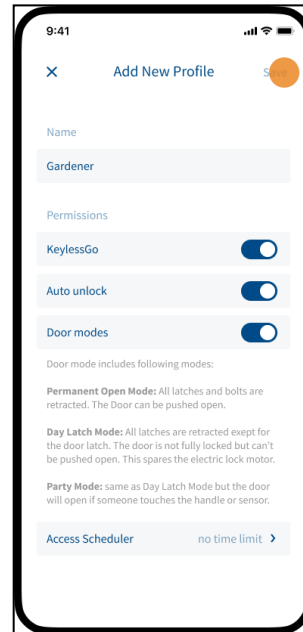

Tap **Save** to save the profile.

**Note:** A maximum of eight individual profiles can be created.

## 7.2. Edit Profiles

1 Tap the **three dots icon** in the top right corner and choose **Profiles**.

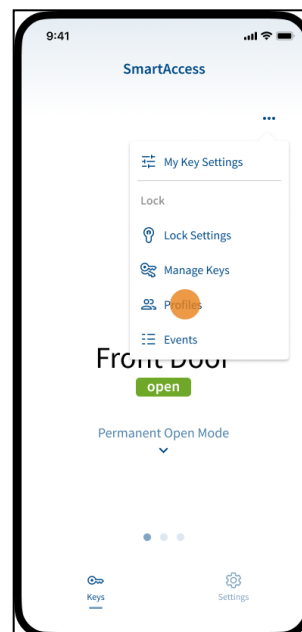

2 All profiles of the **SmartAccess Module** are listed here. The profiles "Admin" and "Blocked" are immutable and can't be removed. All other profiles can be adjusted or removed.

To adjust the settings of a profile tap the *profile* you want to edit.

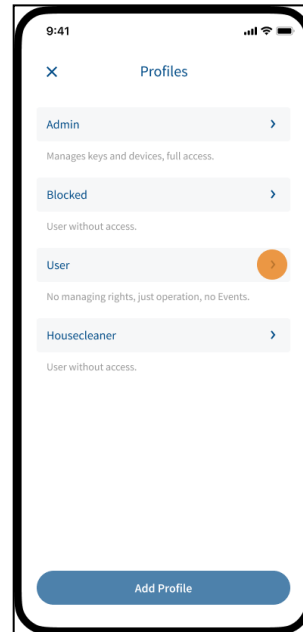

3 You now have the possibility to adjust the settings of the profile. E.g. change permissions or add an Access Scheduler.

To grant permissions for features like KeylessGo, Auto unlock or door modes activate the corresponding *toggle switch*.

To adjust an access scheduler tap **Access Scheduler**. For more information about access schedulers, see chapter [Access Schedulers < https://docs.smartwireless.de/en/access-scheduler/>](https://docs.smartwireless.de/en/access-scheduler/).

To save the changes you made, tap **Save** in the top right corner.

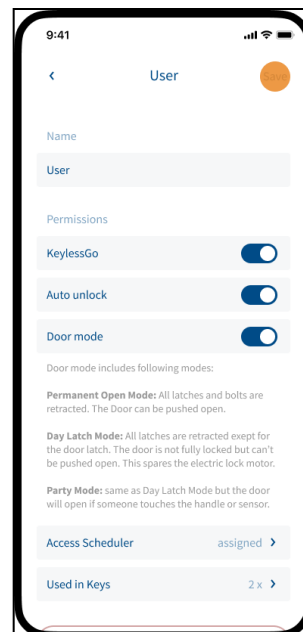

## 7.3. Remove Profiles



1 Tap the **three dots icon** in the top right corner and choose **Profiles**.

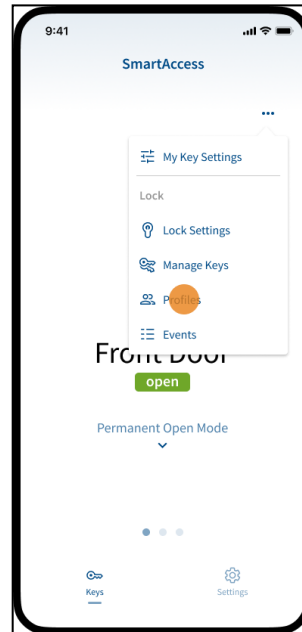

2 All **profiles** of the **SmartAccess Module** are listed here. The profiles **Admin** and **Blocked** are immutable and can't be removed. All other profiles can be removed.

Tap the **profile** you want to remove.

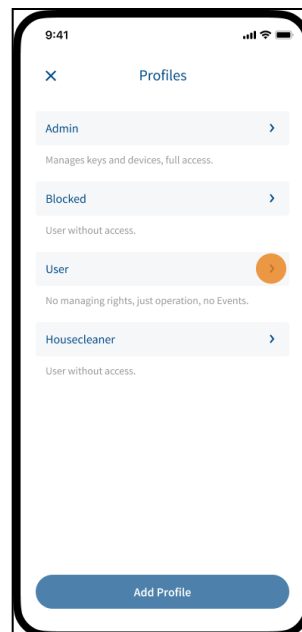

3 To remove the profile scroll down and tap **Remove Profile**.

**Note:** Profiles that are in use cannot be removed.

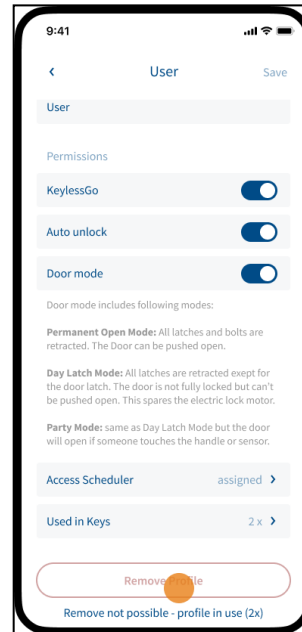

## 7.4. Features

### KeylessGo

Activate the toggle switch if you want to assign the use of KeylessGo to the profile.

For further information on how KeylessGo works, see chapter [How does KeylessGo work < https://docs.smartwireless.de/en/how-does-keylessgo-work/>](https://docs.smartwireless.de/en/how-does-keylessgo-work/) .

### Auto Unlock

Activate the toggle switch if you want to assign the use of Auto Unlock to the profile.

**Note:** If Auto unlock is enabled, the door is opened as soon as an authorized key is within the Bluetooth range of the **SmartAccess Module**. The door can be pushed open without touching the door handle or sensor. Make sure that you actually enter the door after entering the Bluetooth range of the **SmartAccess Module**, otherwise the door will remain open!

### Door mode

Activate the toggle switch if you want to assign the use of different door modes (Day Latch Mode, Permanent Open Mode and Party Mode) to the profile.

For further information about the individual door modes, see chapter [Door modes < https://docs.smartwireless.de/en/door-modes/>](https://docs.smartwireless.de/en/door-modes/) .

## 8. ADD & EDIT ACCESS SCHEDULERS

As an Administrator you can decide whether, when, and for which time frames users can use the **SmartAccess Module**. You can assign time limited permissions which are only active at certain days or at certain times of the day by setting up access schedulers (e.g. for cleaning staff or employees).

Access schedulers are always linked to a profile. In order to grant a user time restricted permission, the time restricted permission must be set up via the corresponding profile.

For more information on how to assign a profile to a user, see chapter [Add and manage Keys < https://docs.smartwireless.de/en/add-users/>](https://docs.smartwireless.de/en/add-users/).

**Note:** If you set up a time restricted permission to a profile, this time restricted permission applies to all users to whom this profile has been assigned.

### 8.1. Add Access Scheduler

1 Tap the **three dots icon** in the top right corner and choose **Profiles**.

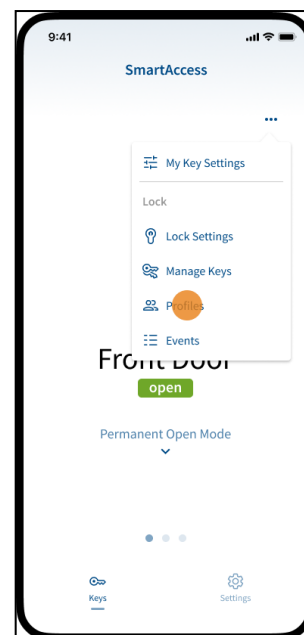

2 All profiles of the **SmartAccess Module** are listed here. The profiles "Admin" and "Blocked" are immutable and can't be removed. All other profiles can be adjusted or removed.

To assign a new access scheduler to a profile tap the *profile*.

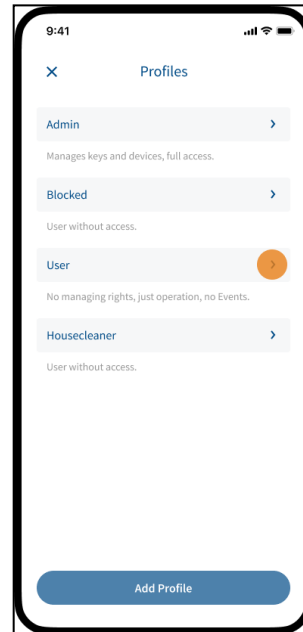

3 Tap **Access Scheduler** to add a new access scheduler.

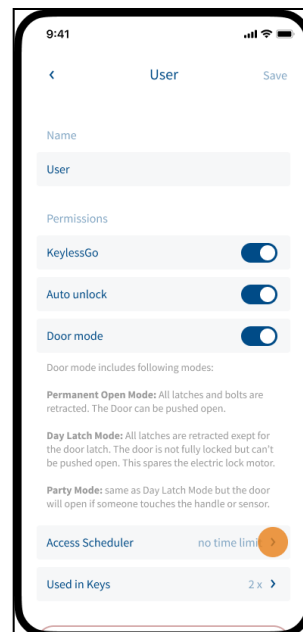

4 Set the **Date range** and/or **Weekdays** and/or **Time of the Day**. The settings can be made independently of each other.

**Note:** A table with explanations of the individual conditions can be found at the end of this chapter.

Tap **Save** to save the access scheduler.

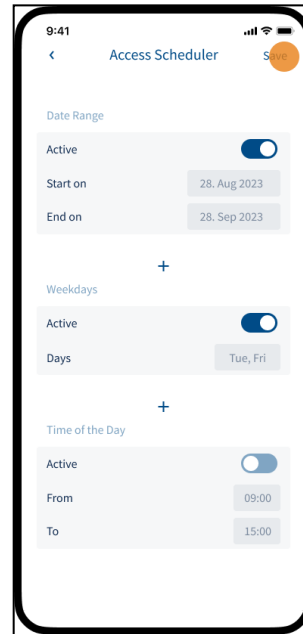

## 8.2. Edit Access Scheduler

1 Tap the **three dots icon** in the top right corner and choose **Profiles**.

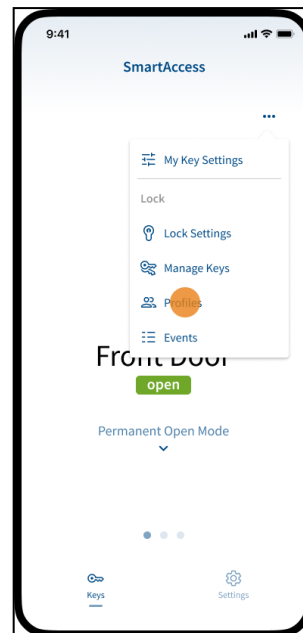

2 All profiles of the **SmartAccess Module** are listed here. The profiles "Admin" and "Blocked" are immutable and can't be removed. All other profiles can be adjusted or removed.

To adjust the settings of an existing access scheduler of a profile, tap the **profile**.

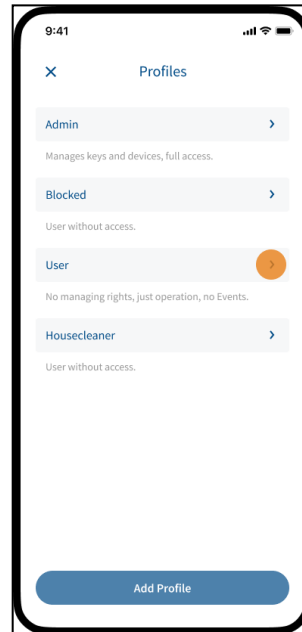

3 Tap **Access Scheduler** to adjust the settings of the access scheduler.

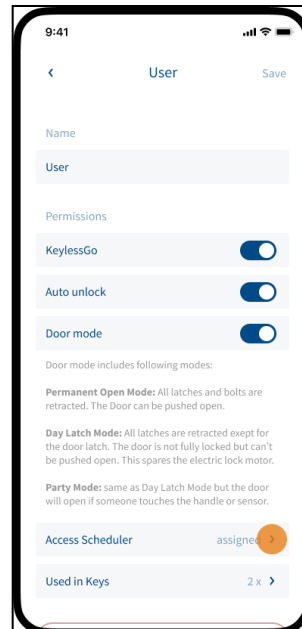

4 Adjust the **Date range** and/or **Weekdays** and/or **Time of the Day**. The settings can be made independently of each other.

**Note:** A table with explanations of the individual conditions can be found at the end of this chapter.

To save the adjustments tap **Save** in the top right corner.

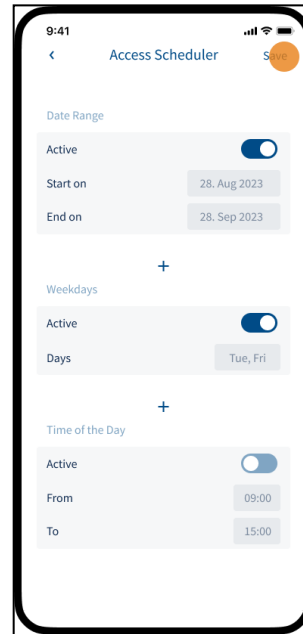

### 8.3. Disable Access Scheduler

1 Tap the **three dots icon** in the top right corner and choose **Profiles**.

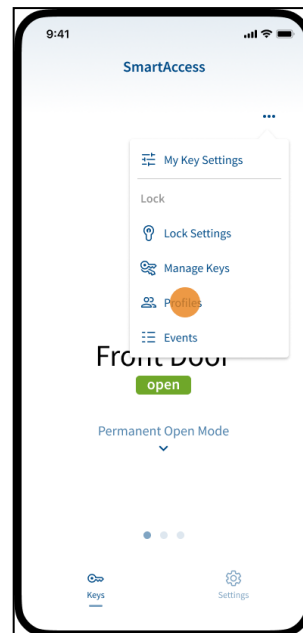

2 All profiles of the **SmartAccess Module** are listed here. The profiles "Admin" and "Blocked" are immutable and can't be removed. All other profiles can be adjusted or removed.

To disable an access scheduler of a profile, tap the *profile*.

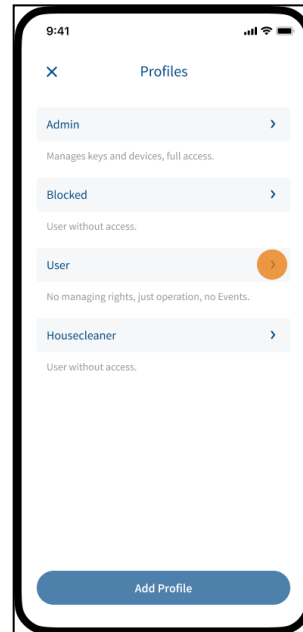

3 Tap **Access Scheduler** to disable the access scheduler.

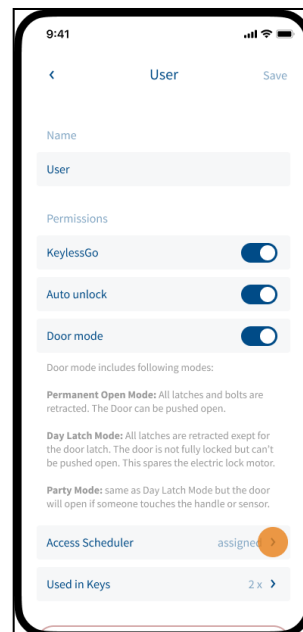



4 Deactivate the *toggle switches* of **Date range**, **Weekdays** and **Time of the Day**.

**Note:** In order to disable an access scheduler all three toggle switches have to be deactivated!

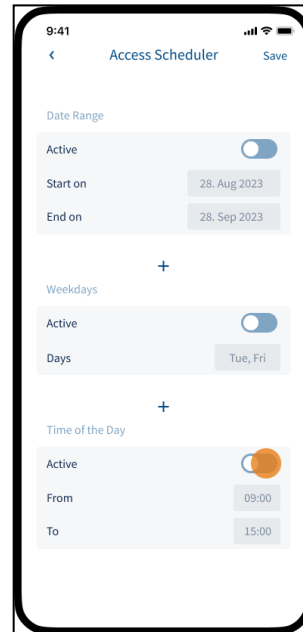

5 To disable the access scheduler tap **Save** in the top right corner.

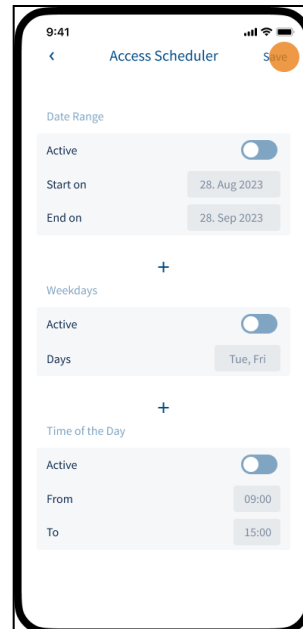

## 8.4. Conditions of Access Schedulers

You can create completely individual access schedulers by activating the corresponding switches and adjusting the parameters Date range and/or Weekdays and/or Time of the day according to your wishes.

For example, you can only set the date range or define more precisely on which days of the week and at what times the access scheduler should be active.

### Date Range

The date range defines from and to which date a access scheduler should be active.

## **Weekdays**

You can use weekdays to specify the days of the week on which the schedule should be active.

## **Time of the Day**

You can use time of the day to specify certain times of day when the schedule should be active.

## 9. EVENTS

All actions performed by the **SmartAccess Module** are recorded in the Events area. This means you can see which user opened or closed the door at what time.

**Note:** The entries in the Events area can only be accessed if the smartphone is within the Bluetooth range of the **SmartAccess Module**.

1 Tap the **three dots icon** in the top right corner and choose **Events**.

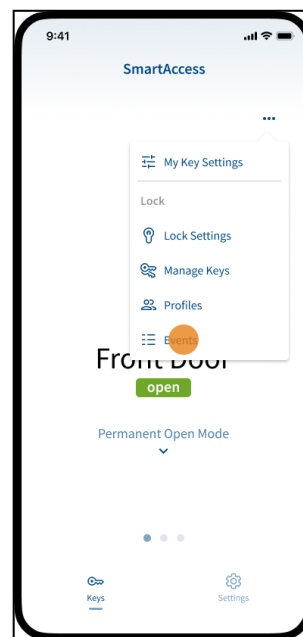

2 All actions performed by the **SmartAccess Module** are listed here.

Scroll down to view older events.

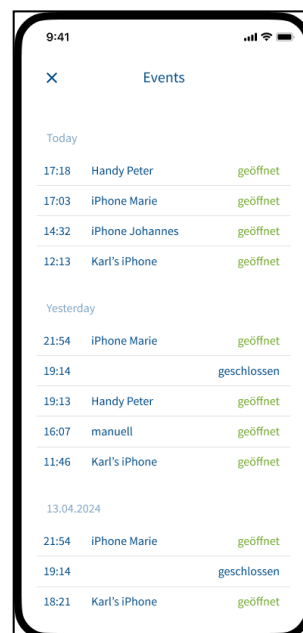

## 10. DOOR MODES

SmartAccess offers the option of activating different door modes.

### 10.1. Day Latch Mode

When the **Day Latch Mode** is engaged, only the latch secures the door. This spares the electric motor lock while still ensuring controlled access.

Ideally suited to heavily frequented doors such as commercial or apartment buildings.

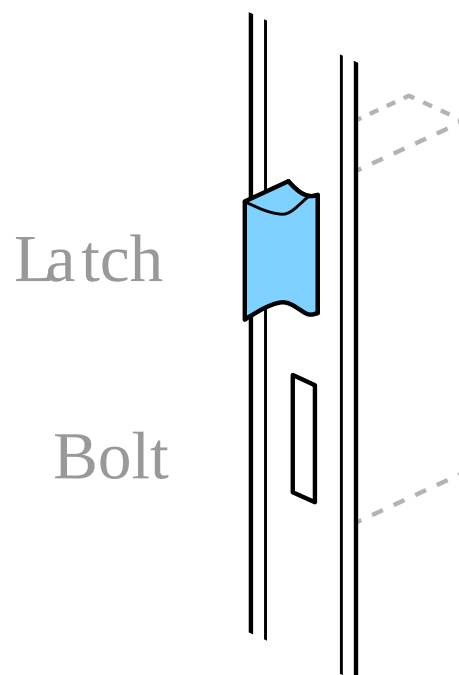

### 10.2. Permanent Open Mode

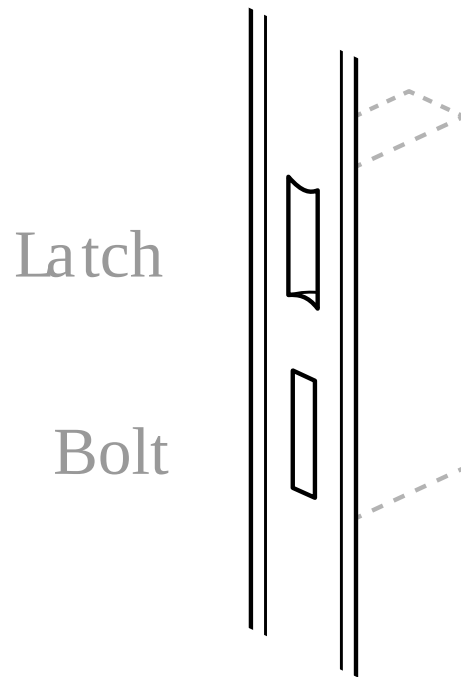

When the **Permanent Open Mode** is activated, the latch and all bolts are permanently retracted. Unrestricted access in both directions is possible. The door can be pushed open without access control.

Ideally suited for shops, surgeries or other buildings frequently visited by the public. In a residential setting this function is convenient if, for example, the user is working in the garden and keeps going in and out.

### 10.3. Party Mode

When the **Party Mode** is activated, only the latch secures the door (same as Day Latch Mode). By touching the SmartTouch handle or the SmartTouch sensor, the latch is retracted and the door can be pushed open without access control.

Ideally suited for a party where the door needs to be locked but guests can go in and out undisturbed.

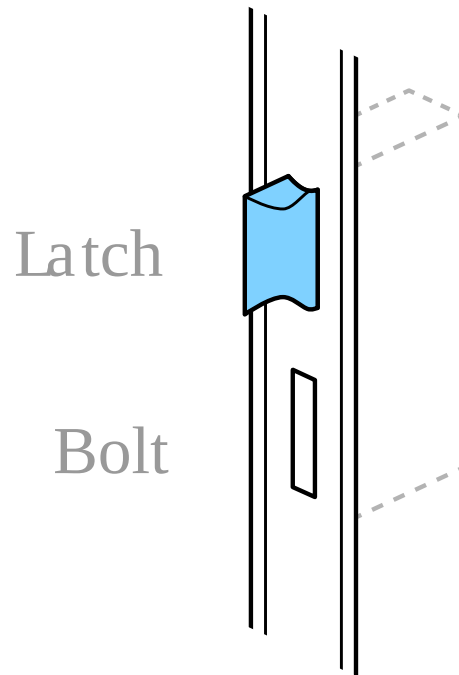

## 10.4. Activate Door Modes

1 Tap *Options*.

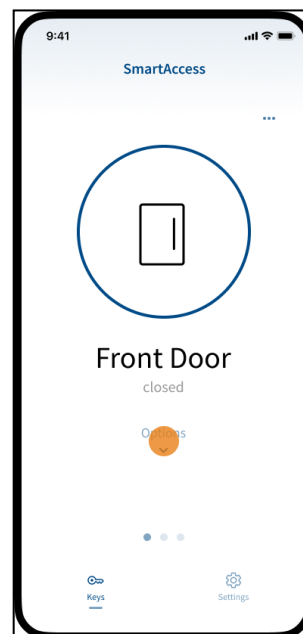

2 A pop-up appears with the individual door modes.

Activate the desired door mode by activating the corresponding **toggle switch**.

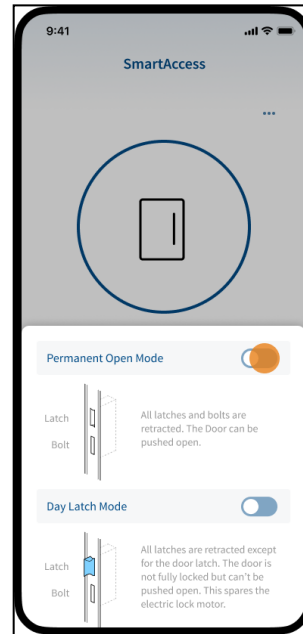

3 Set the time until when the door mode should be active.

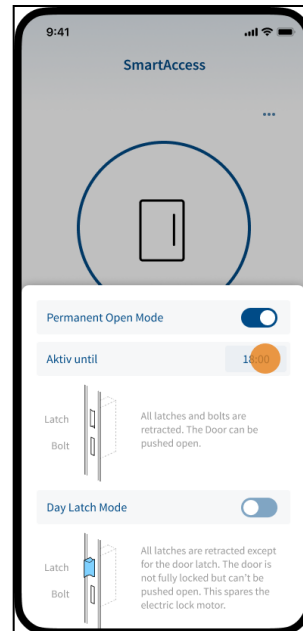

4 Tap *anywhere outside the pop-up* to close the pop-up and activate the door mode.

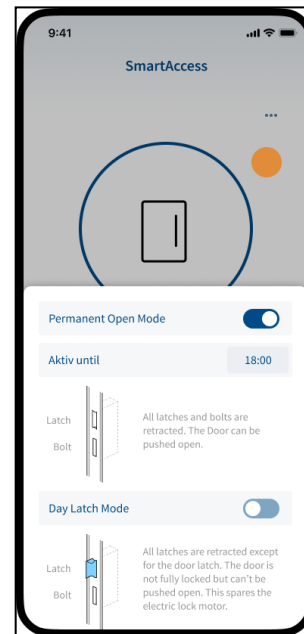

**Note:** The activation of door modes is only possible if the administrator has enabled the use of door modes in the Lock Settings area and has granted you the permission to activate door modes. For further information on how to enable door modes, see chapter [Lock Settings < https://docs.smartwireless.de/en/manage-device/>](https://docs.smartwireless.de/en/manage-device/). For further information on granting permissions, see chapter [Add and edit Profiles < https://docs.smartwireless.de/en/profiles/>](https://docs.smartwireless.de/en/profiles/) and [Add and manage Keys < https://docs.smartwireless.de/en/add-users/>](https://docs.smartwireless.de/en/add-users/).



# 11. SMARTKEYS

## 11.1. Button Assignments

1 Tap the **three dots icon** in the top right corner and choose **Manage Keys**.

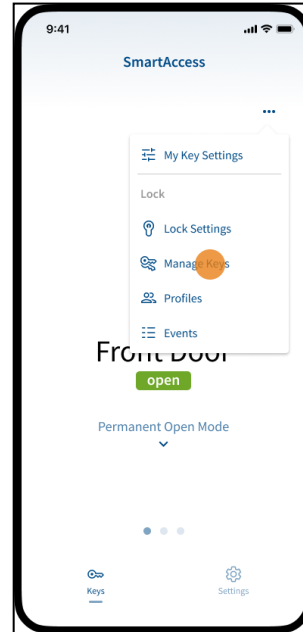

2 All keys of the **SmartAccess Module** are listed here.

Select the **SmartKey** whose button assignments you want to edit.

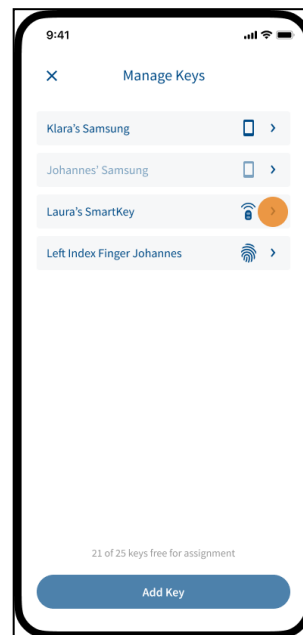

**3 Tap *Button Assignments*.**

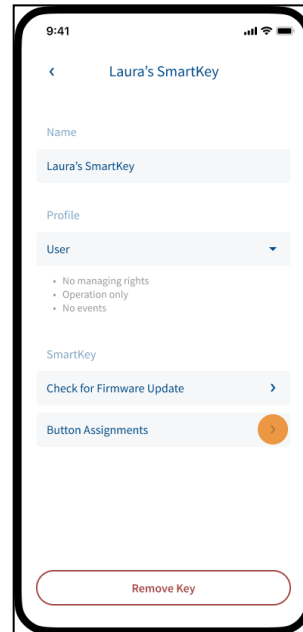

**4 To access the SmartKey, it has to be set to edit mode.**

**To set the SmartKey to edit mode:**

1. Make sure the SmartKey is located near your **SmartAccess Module**.
2. Press buttons 2 and 4 on the SmartKey.

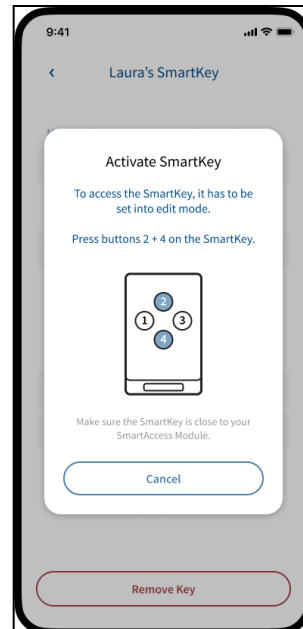

5 Wait until the SmartKey is activated.

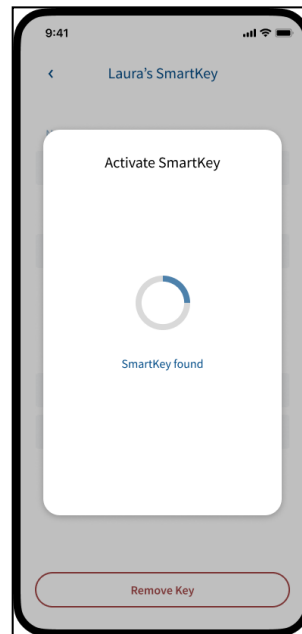

6 The button assignments of the SmartKey are displayed.

To delete an existing button assignment, tap on the corresponding ***delete icon***.

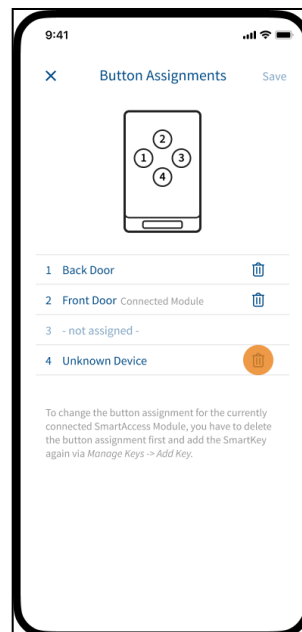

7 Confirm the pop-up by tapping **Delete Button Assignment**.

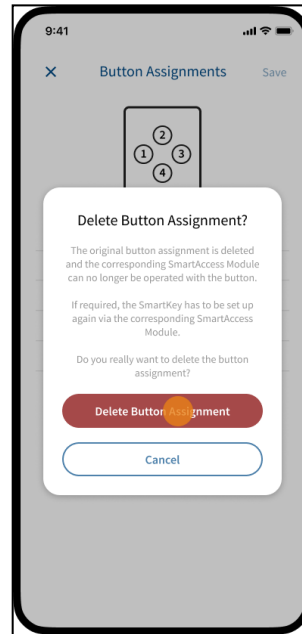

8 To save the changes you made, tap **Save** in the top right corner.

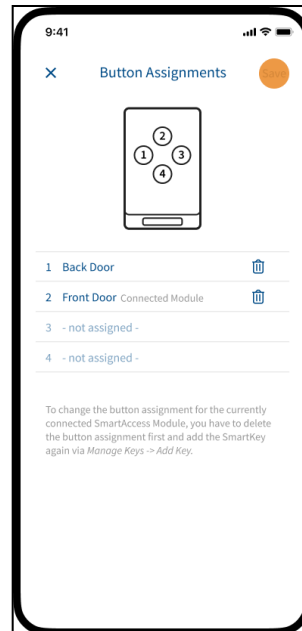

9 To complete the process the SmartKey has to be set to edit mode again.

**To set the SmartKey to edit mode:**

1. Make sure the SmartKey is located near your SmartAccess Module.
2. Press buttons 2 and 4 on the SmartKey.

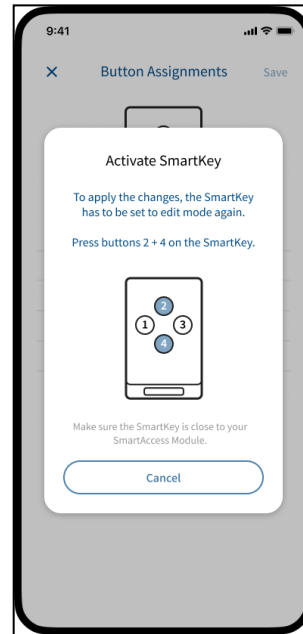

10 Wait until the SmartKey is activated.

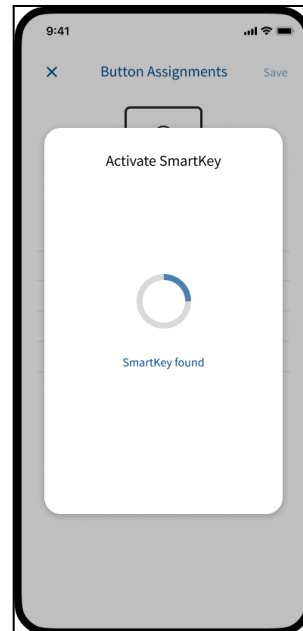

11 The button assignment has been successfully changed.

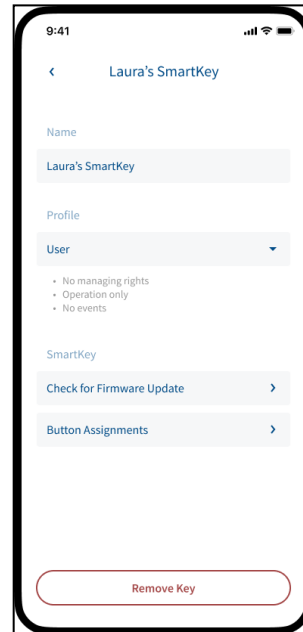

**Note:** If you delete the button assignment for a **SmartAccess Module** that is **currently not connected**, the corresponding **SmartAccess Module** can no longer be operated with the button.

If required, the SmartKey has to be set up again via the corresponding **SmartAccess Module**.

**Note:** If you delete the button assignment for the **currently connected SmartAccess Module**, the SmartKey is automatically removed.

To use the SmartKey again with the currently connected **SmartAccess Module**, you have to add the SmartKey again via **Manage Keys -> Add Key**. Further information on how to add keys, see chapter **Add and manage Keys** < <https://docs.smartwireless.de/en/add-users/> >.

## 11.2. Firmware Update (SmartKey)

1 Tap the **three dots icon** in the top right corner and choose **Manage Keys**.

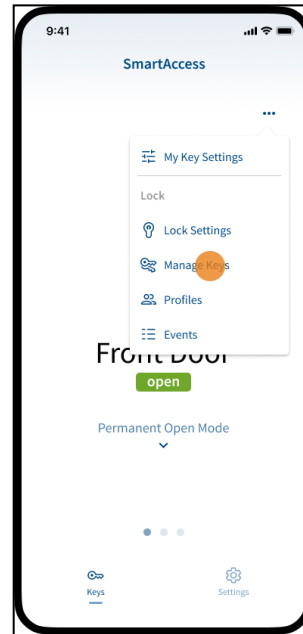

2 All keys of the **SmartAccess Module** are listed here.

Select the **SmartKey** for which you want to perform a firmware update.

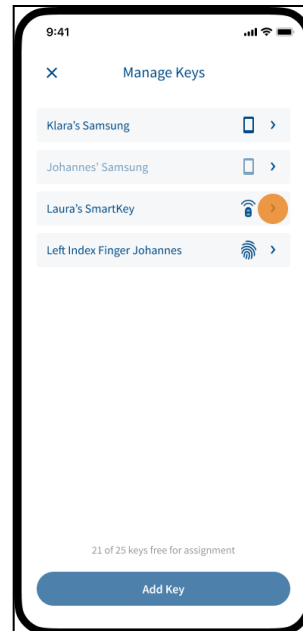

**3 Tap *Check for Firmware Update*.**

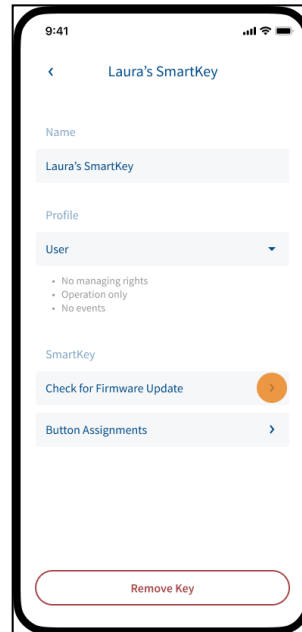

**4 To access the SmartKey, it has to be set to edit mode.**

**To set the SmartKey to edit mode:**

1. Make sure the SmartKey is located near your SmartAccess Module.
2. Press buttons 2 and 4 on the SmartKey.

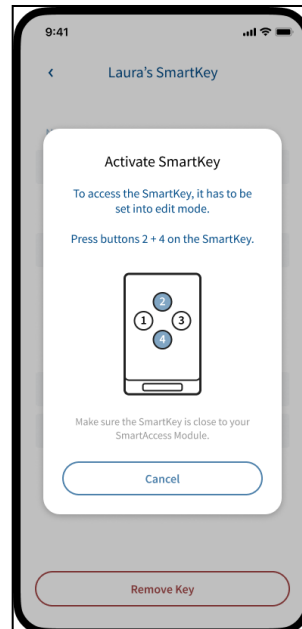



5 Wait until the SmartKey is activated.

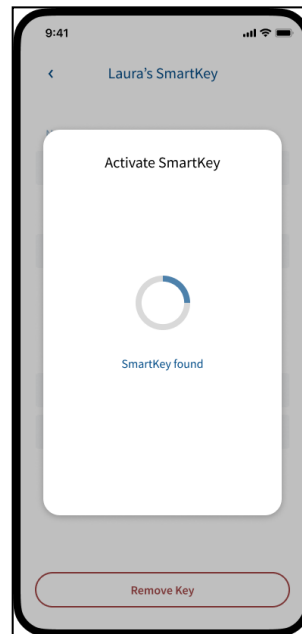

6 If a firmware update is available, it will be displayed here.

To perform the firmware update, tap **Start Update**.

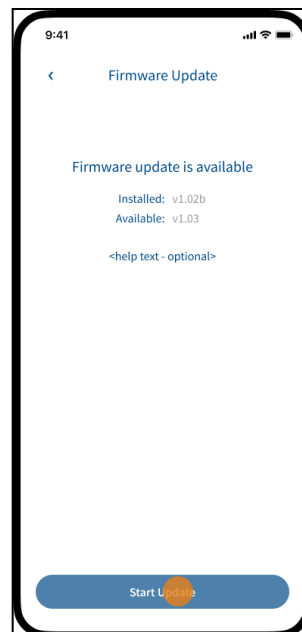

7 To complete the process the SmartKey has to be set to edit mode again.

**To set the SmartKey to edit mode:**

1. Make sure the SmartKey is located near your SmartAccess Module.
2. Press buttons 2 and 4 on the SmartKey.



8 Wait until the SmartKey is activated.

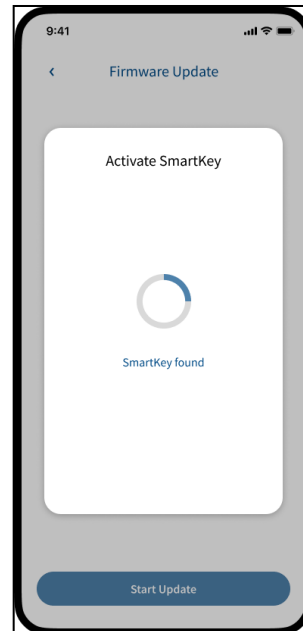

9 Wait until the firmware update is complete.

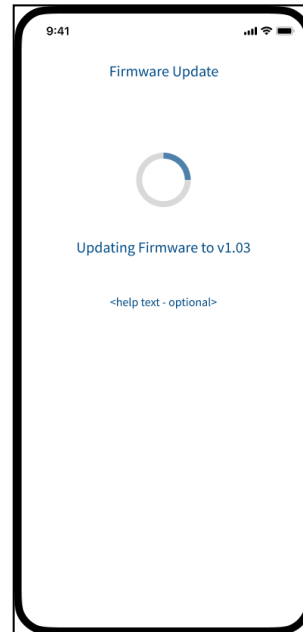

10 The firmware has been successfully updated.

Tap **Done** to complete the process.

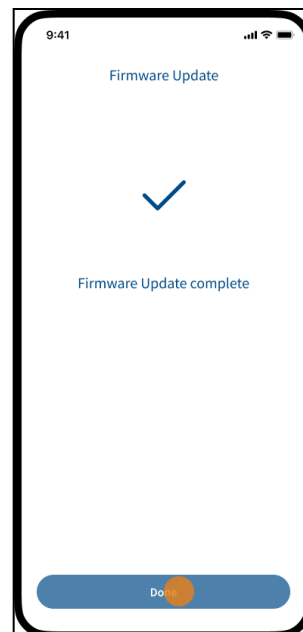

### 11.3. Charge level of the SmartKey battery

If SmartKey batteries are low, this will reduce the radio range. The SmartKey measures the amount of charge remaining in the battery by pressing its transmit button. If the battery is too low, the LED of the SmartKey flashes 3 times when its transmit button is pressed. If this happens, please replace the battery promptly. All stored data remain saved when changing the battery.

**Note:** Please change the batteries in time, if the batteries are completely empty you cannot open the door with the SmartKey anymore.

### 11.4. Battery change

The SmartKey is operated by a battery type CR2032. Immediately it is ready for use just after changing the battery.

Please proceed as follows when changing the batteries:

1. Insert a narrow object (such as a flat-head screwdriver) into the slot at the back of the SmartKey and gently lever the cover up.
2. Replace the battery, making sure the polarity is correct (the positive pole must be visible).
3. Close the case.

1.

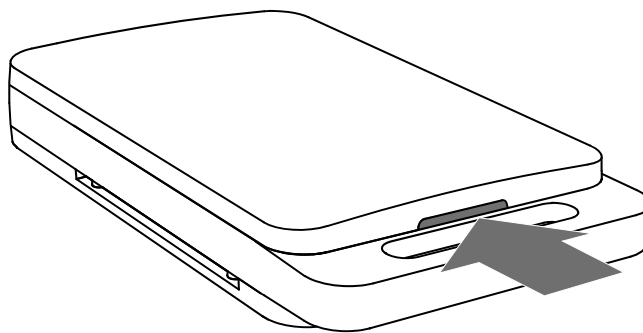

2.

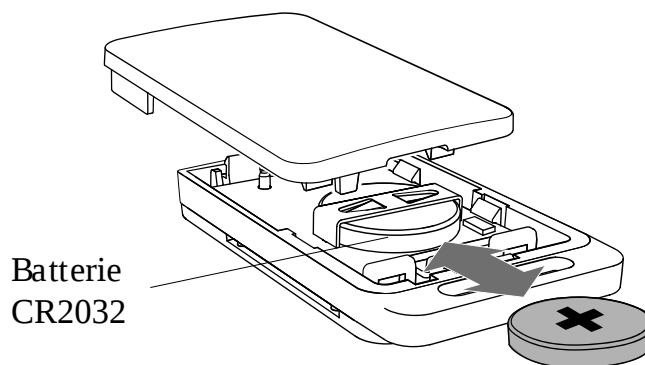

## 11.5. Range of the KeylessGo function

The distance in which a SmartKey responds to the radio signal of the **SmartAccess Module** varies significantly with environmental conditions. If the SmartKey is significantly further away than 1 meter from the door, it usually does not respond. Electrically conductive objects e.g. can increase this distance. The requirement for a SmartKey to respond after touching the SmartTouch handle or SmartTouch sensor is in any case that it is in motion.

Please note that SmartKeys can also be detected from the **SmartAccess Module** when you are inside the building under the following conditions:

1. The SmartKey is located inside the KeylessGo radio range (please determine this area individually at your own door) and
2. within the last 3 seconds the SmartKey was in motion.

Note the additional security functions in the next chapter.

For safety reasons, we recommend to lay the SmartKey down when you are inside the building. The motion sensor is then deactivated after 3 seconds and unauthorised opening of the door is no longer possible.

## 11.6. Automatically switching off function of the SmartKeys

For safety reasons, all SmartKeys are fitted with a motion sensor. If a SmartKey is not moved for 3 seconds, it automatically switches off by itself. If the SmartKey is within the detection radius of the **SmartAccess Modul**, the deactivation prevents unauthorized door opening via KeylessGo. Furthermore the deactivation mode saves battery power. You can activate the sensor again by moving the SmartKey and open the door, as usual, via KeylessGo function.

## 12. HOW DOES KEYLESSGO WORKS

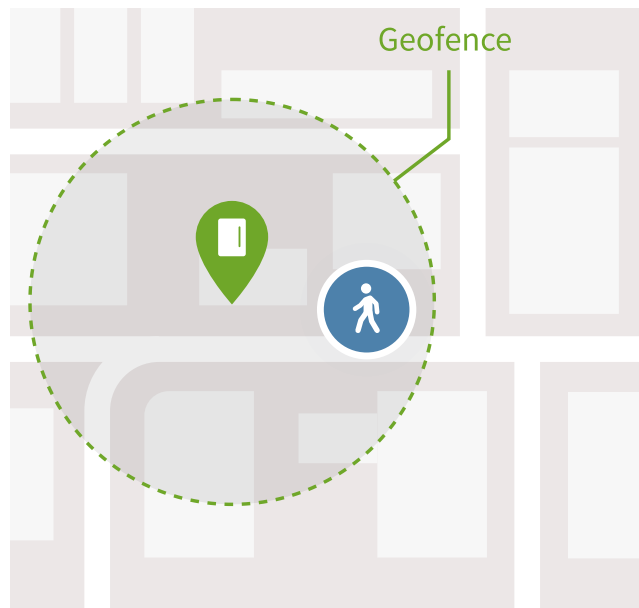

### Entering Geofence area

The Geofence area is a like fence drawn around the **SmartAccess Module**. When entering KeylessGo get's armed. The **SmartAccess App** starts scanning for a **SmartAccess Module**.

If KeylessGo is not used within 15 min you need to leave the Geofence and reenter to enable KeylessGo again.

Nevertheless opening the door manually via the **SmartAccess App** still works.

## Approaching door entering Bluetooth area

The Bluetooth area is the area in which the **SmartAccess Module** can communicate with the smartphone via Bluetooth. When entering this area the **SmartAccess App** establishes a connection to the **SmartAccess Module** or door. Inside this area the door can be opened via the **SmartAccess App**.

If KeylessGo is not used within 1 min you need to leave the Bluetooth area and reenter to enable KeylessGo again.

Nevertheless opening the door manually via the **SmartAccess App** still works.

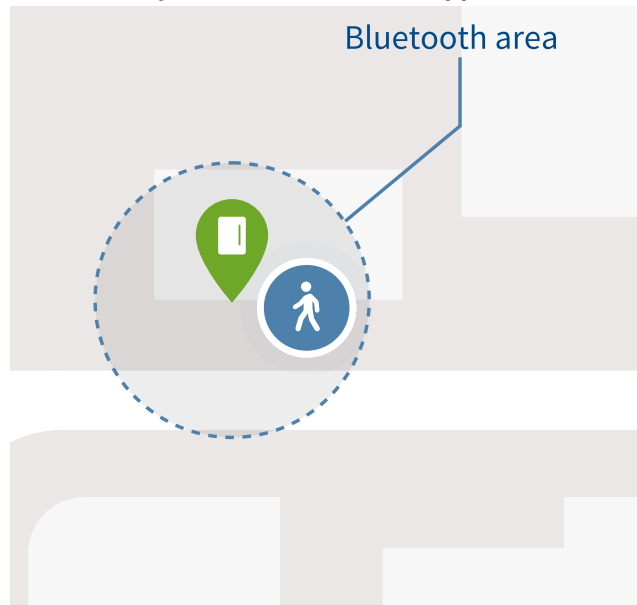

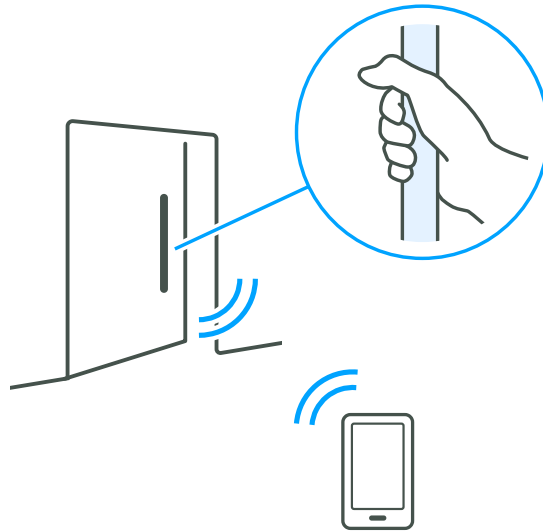

## Grabbing the door handle or touching the sensor

The door unlocks and can now be pushed open.

With Auto unlock enabled the door can be pushed open without grabbing the door handle or touching the sensor.

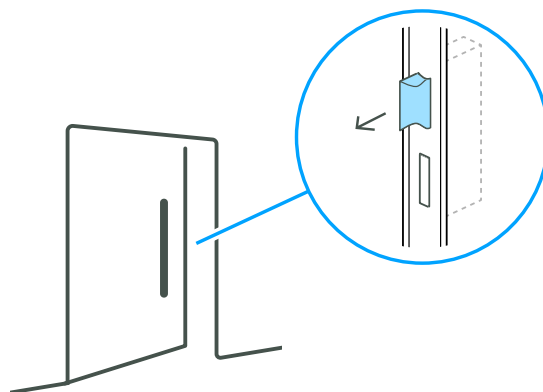

## After opening the door

The latch gets extracted immediately after opening the door.



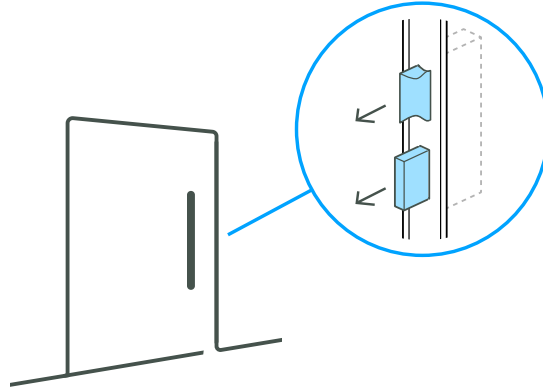

## Closing the door

After closing the door get's fully locked again

Functionality depends on lock type  
(All motorised FUHR locks support this feature).

## 13. RESET (FACTORY SETTINGS)

**Note:** If you perform a reset, the **SmartAccess Module** is set to the factory settings. All settings and keys will be lost!

1 Tap the **three dots icon** in the top right corner and choose **Lock Settings**.

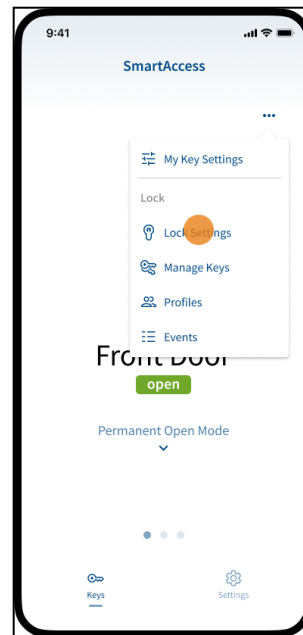

2 Scroll down and tap **Reset SmartAccess Module**.

**Note:** Tap and drag the blue floating Info Button to the side if it is in the way.

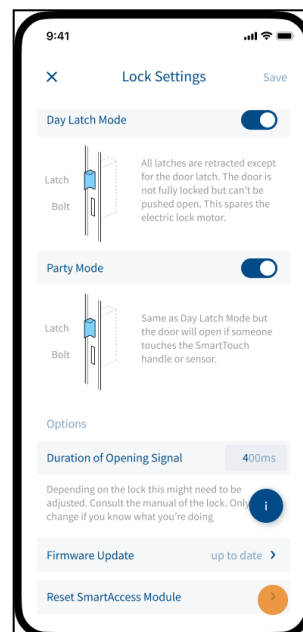

3 Confirm the pop-up by tapping **Reset**.

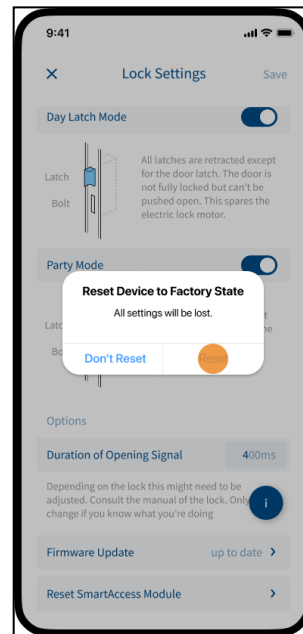

# 14. FIRMWARE UPDATE

**Note:** Please keep the door closed during the entire update process, otherwise the **SmartAccess Module** will not be supplied with power and the update cannot be carried out properly.

1 Tap the **three dots icon** in the top right corner and choose **Lock Settings**.

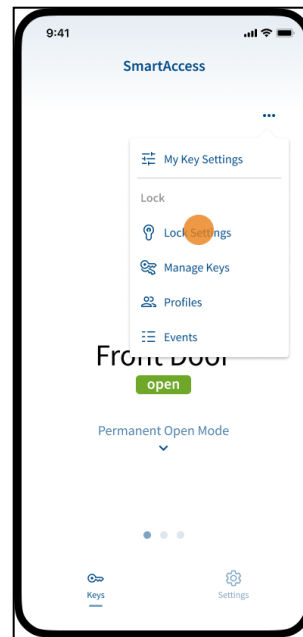

2 Scroll down and tap **Firmware Update**.

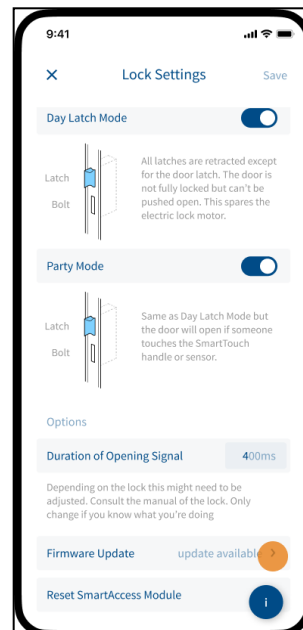

3 Tap *Start Update*.

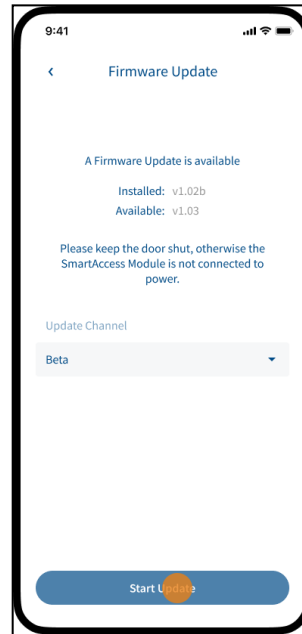

4 Wait until the update is complete.

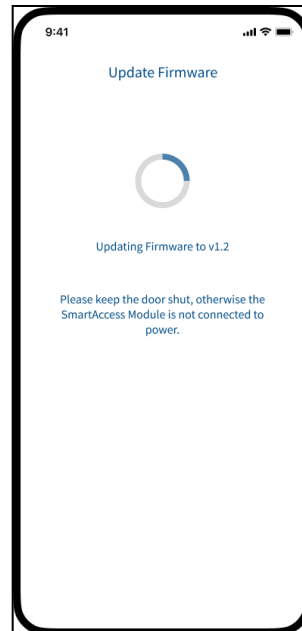

5 Tap *Close*.

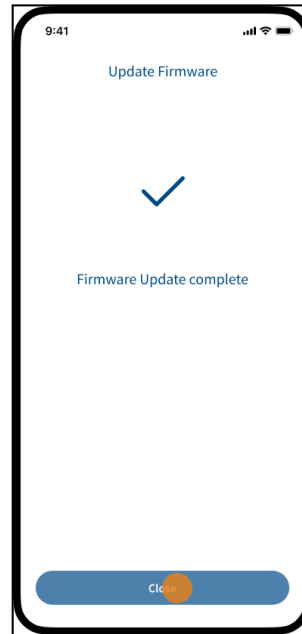

# 15. DOWNLOADS SMARTACCESS

## 15.1. SmartAccess

SmartAccess Manual (PDF) < <https://docs.smartwireless.de/print?url=smartaccess-full-manual?type=sa>>



< [HTTPS://DOCS.SMARTWIRELESS.DE/PRINT?URL=SMARTACCESS-FULL-MANUAL?TYPE=SA](https://docs.smartwireless.de/print?url=smartaccess-full-manual?type=sa)>

SmartAccess Manual English (PDF) < <https://docs.smartwireless.de/print?url=en/smartaccess-full-manual-en?type=sa>>



< [HTTPS://DOCS.SMARTWIRELESS.DE/PRINT?URL=EN/SMARTACCESS-FULL-MANUAL-EN?TYPE=SA](https://docs.smartwireless.de/print?url=en/smartaccess-full-manual-en?type=sa)>